

4

3

2

1

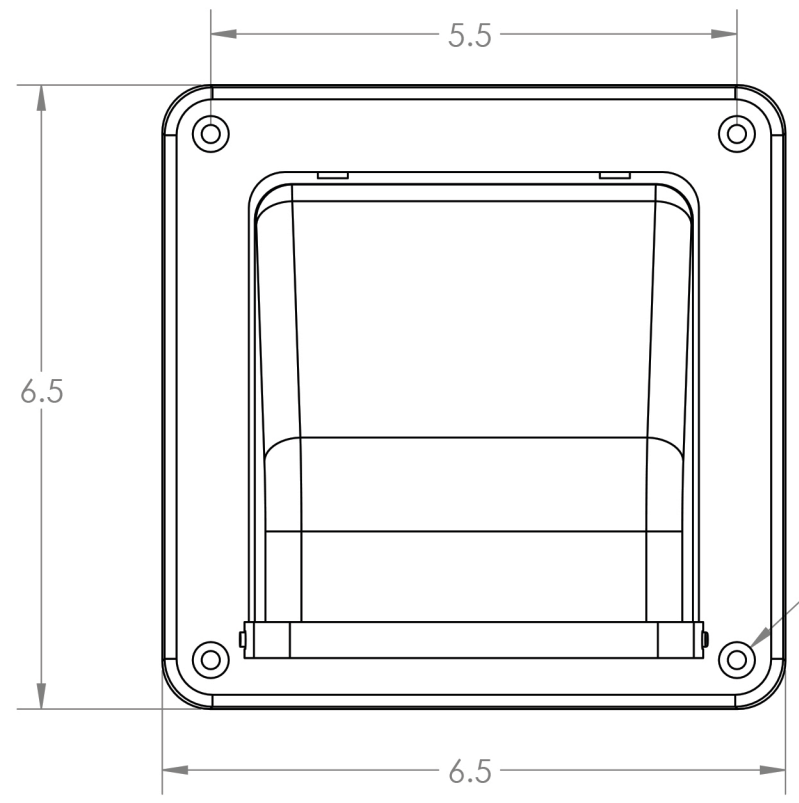

4X ϕ .2 THRU ALL
 \square ϕ .4 ∇ .3

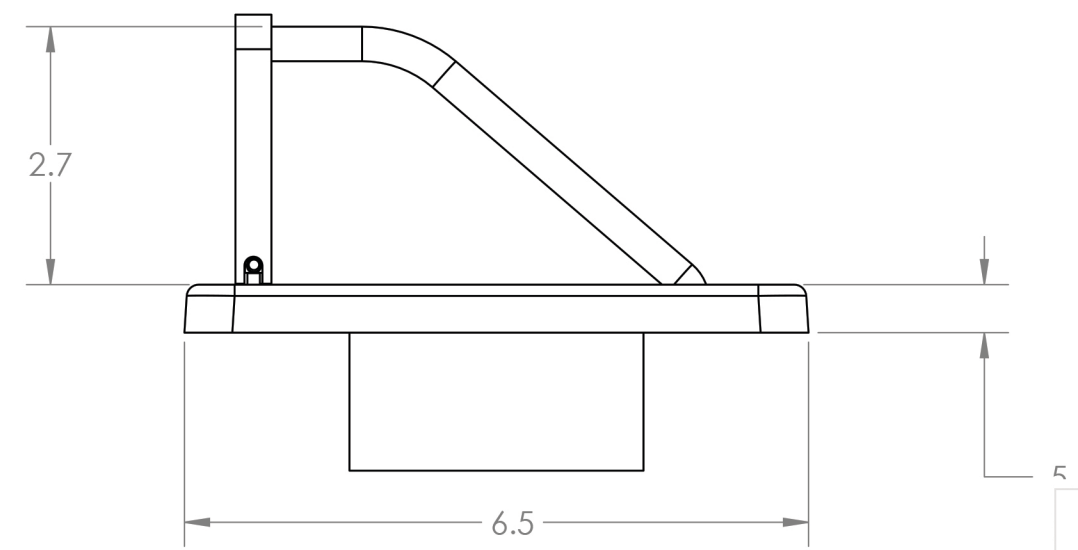
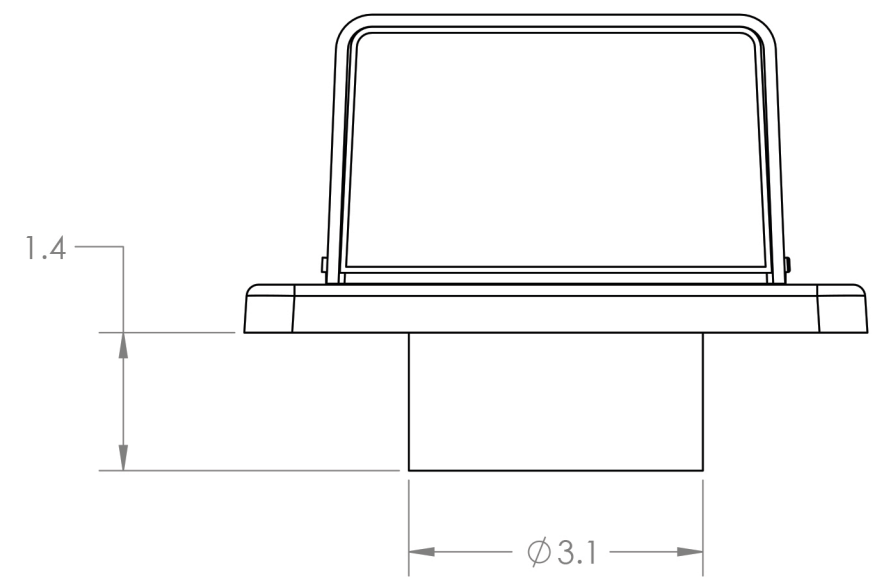
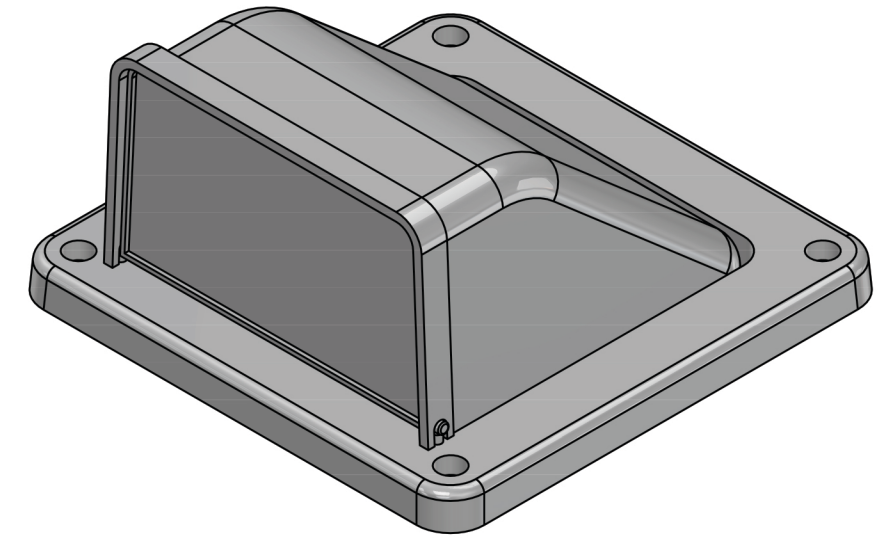

Lambro Industries, Inc.
 115 Albany Ave.
 Amityville, NY 11701
 (631) 842-8088
 www.lambro.net

TITLE: 3" Plastic Soffit Exhaust Hood Vent
 Damper - 1.4" Collar
 Made of polymer resin material with UV inhibitor
 used to help prevent the premature fading of vent

SIZE	DWG. NO.	REV
B	153W	
SCALE: 1:2	WEIGHT:	SHEET 1 OF 1

PROPRIETARY AND CONFIDENTIAL
 THE INFORMATION CONTAINED IN THIS
 DRAWING IS THE SOLE PROPERTY OF
 LAMBRO. ANY REPRODUCTION IN PART
 OR AS A WHOLE WITHOUT THE WRITTEN
 PERMISSION OF LAMBRO IS PROHIBITED.

UNLESS OTHERWISE SPECIFIED:		NAME	DATE
DIMENSIONS ARE IN INCHES		DRAWN	
TOLERANCES:		CHECKED	
FRACTIONAL \pm 1/16		ENG APPR.	
ANGULAR: MACH \pm 1 BEND \pm .01		MFG APPR.	
TWO PLACE DECIMAL \pm 0.01		Q.A.	
THREE PLACE DECIMAL \pm 0.005		COMMENTS:	
INTERPRET GEOMETRIC TOLERANCING PER:		Net Free Area (NFA)	
MATERIAL		11 sq. in.	
FINISH			
NEXT ASSY	USED ON		
APPLICATION		DO NOT SCALE DRAWING	



4

3

2

1

B

B

A

A