

4

3

2

1

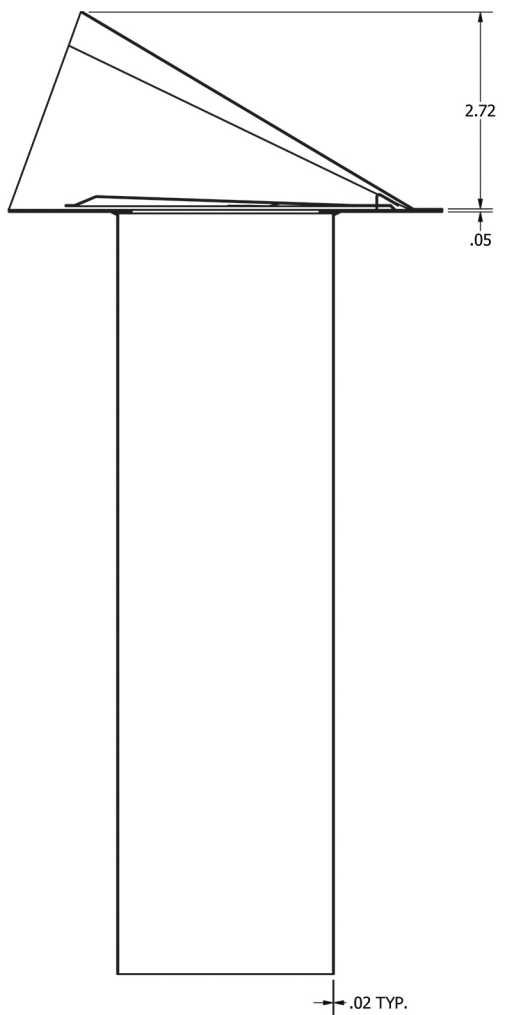
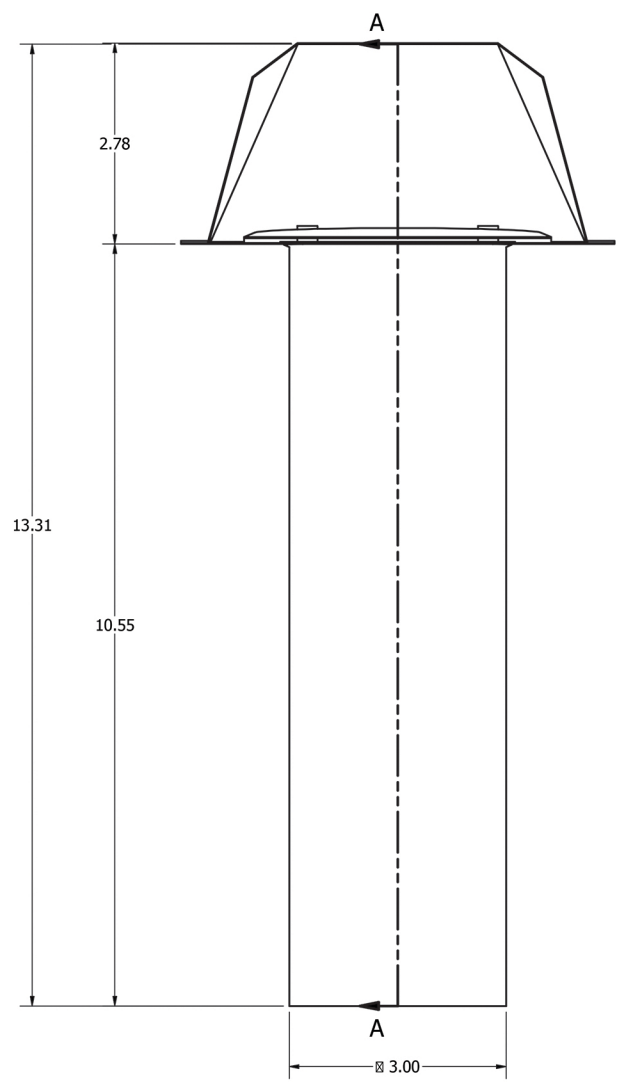

SECTION A-A

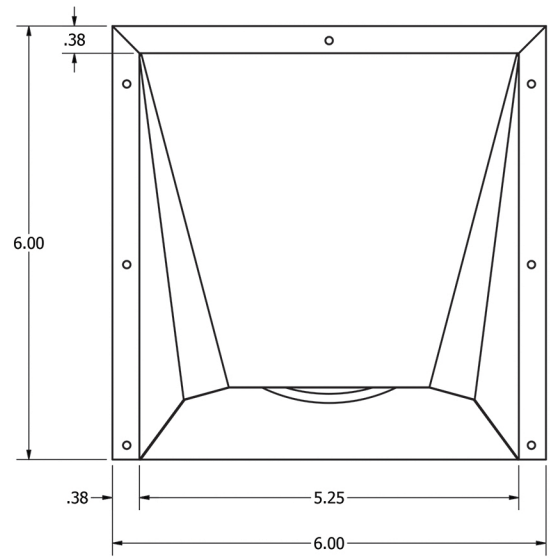
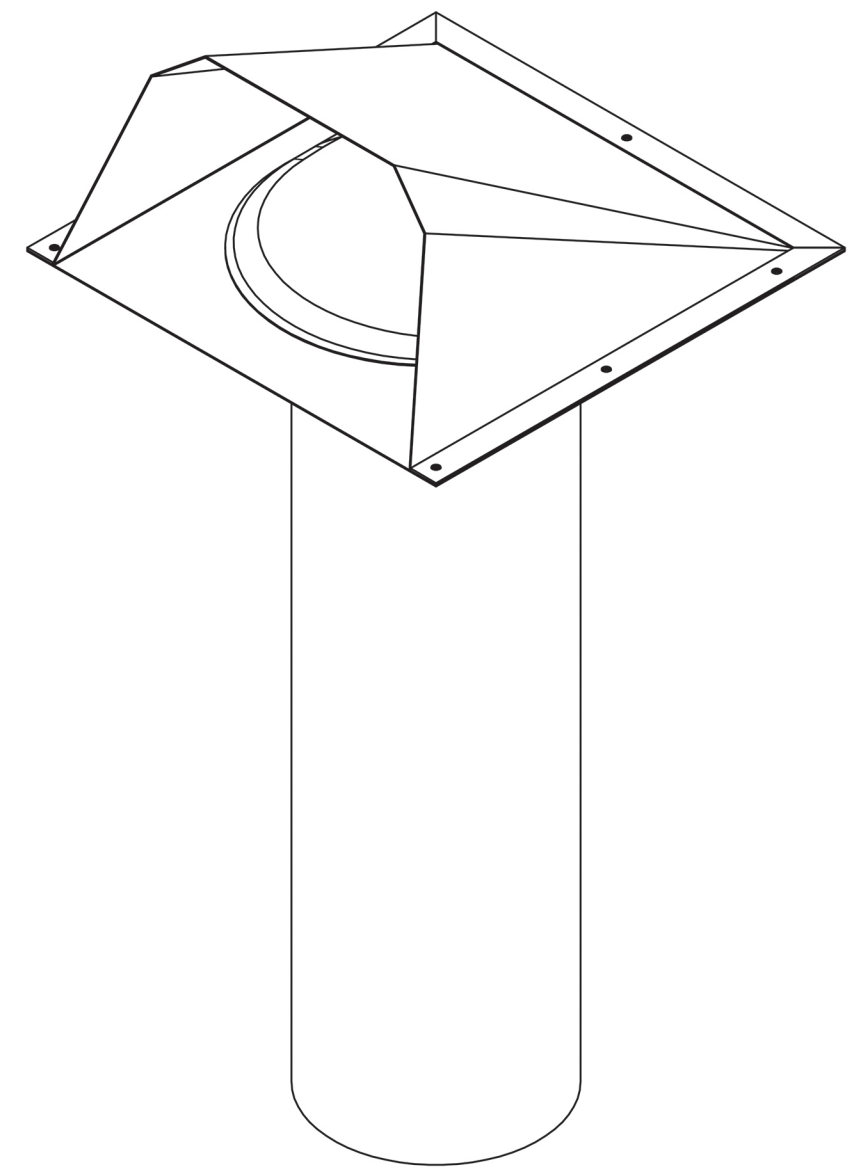

Lambro Industries, Inc.
115 Albany Ave.
Amityville, NY 11701
(631) 842-8088
www.lambro.net

PROPRIETARY AND CONFIDENTIAL
THE INFORMATION CONTAINED IN THIS DRAWING IS THE SOLE PROPERTY OF LAMBRO. ANY REPRODUCTION IN PART OR AS A WHOLE WITHOUT THE WRITTEN PERMISSION OF LAMBRO IS PROHIBITED.

UNLESS OTHERWISE SPECIFIED:		NAME	DATE
DIMENSIONS ARE IN INCHES		DRAWN	
TOLERANCES:		CHECKED	
FRACTIONAL ±1/16		ENG APPR.	
ANGULAR: MACH ±1 BEND ±.01		MFG APPR.	
TWO PLACE DECIMAL ±0.01		Q.A.	
THREE PLACE DECIMAL ±0.005		COMMENTS:	
INTERPRET GEOMETRIC TOLERANCING PER:		Net Free Area (NFA)	
MATERIAL		13.5 sq. in.	
FINISH			
NEXT ASSY	USED ON		
APPLICATION		DO NOT SCALE DRAWING	

TITLE: 3" Aluminum Wall Exhaust Hood Vent Damper - 11" Pipe
Cover, Damper & Base: 26 Gauge
Pipe: 30 Gauge

SIZE	DWG. NO.	REV
B	543	
SCALE: 1:3	WEIGHT:	SHEET 1 OF 1

4

3

2

1

B

B

A

A