

4

3

2

1

B

B

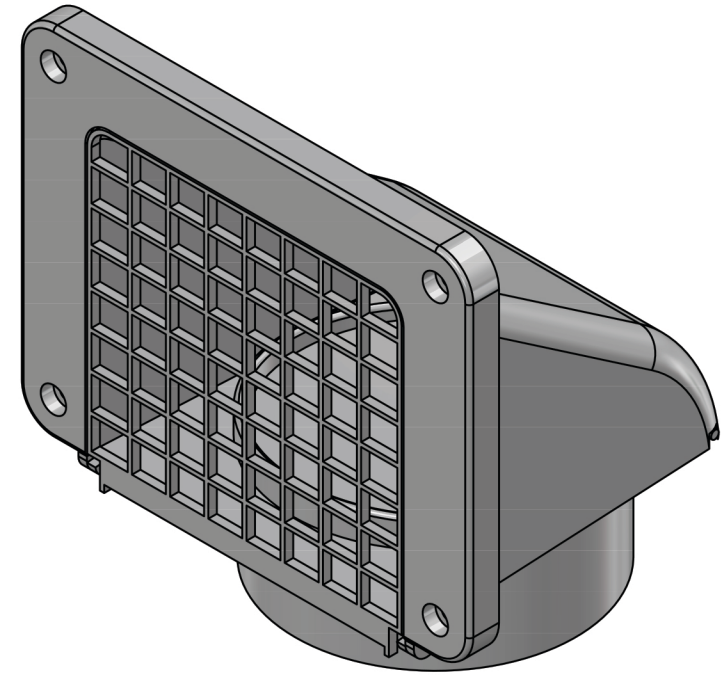
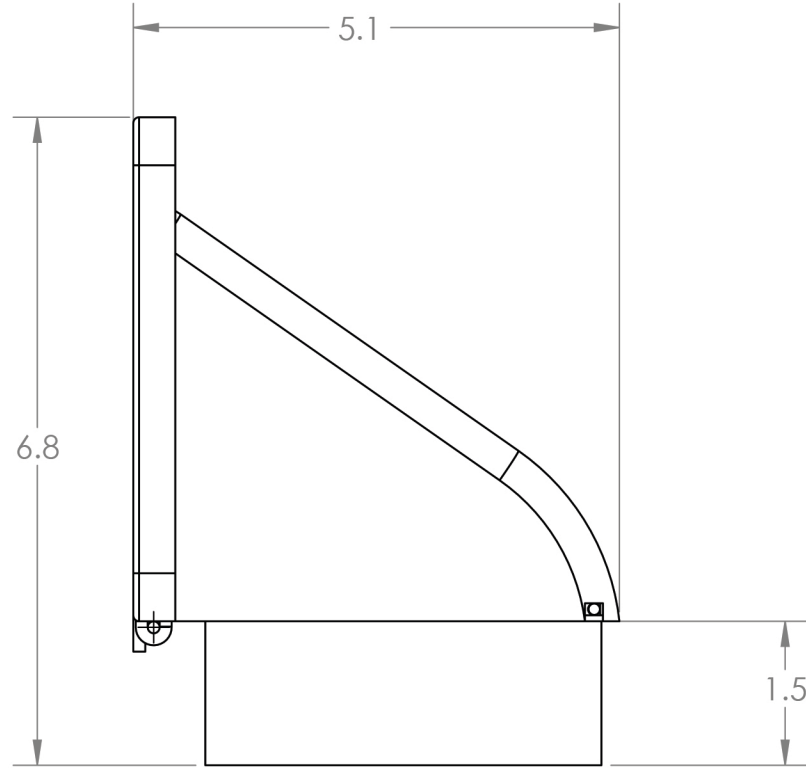
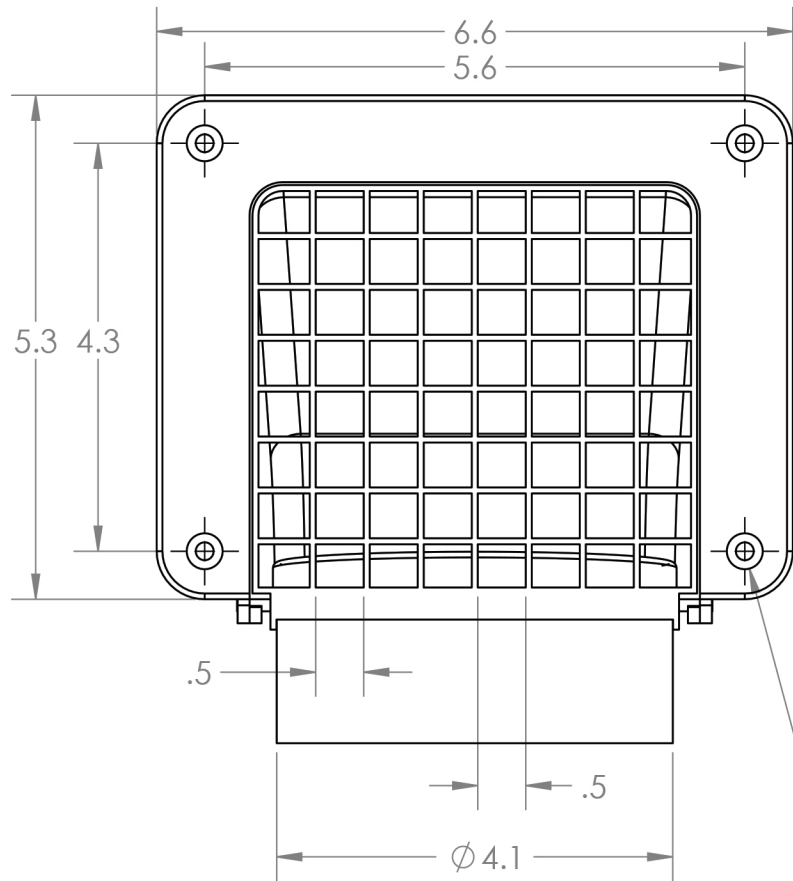

4X Ø .2 THRU ALL
 □ Ø .4 ▽ .2



Lambro Industries, Inc.
 115 Albany Ave.
 Amityville, NY 11701
 (631) 842-8088
 www.lambro.net

TITLE: 4" Plastic Recessed Soffit Exhaust Hood Vent
 Damper - Removable Screen - 1.5" Collar
 Made of polymer resin material with UV inhibitor
 used to help prevent the premature fading of vent

SIZE DWG. NO. REV
B 144W
 SCALE: 1:2 WEIGHT: SHEET 1 OF 1

PROPRIETARY AND CONFIDENTIAL
 THE INFORMATION CONTAINED IN THIS
 DRAWING IS THE SOLE PROPERTY OF
 LAMBRO. ANY REPRODUCTION IN PART
 OR AS A WHOLE WITHOUT THE WRITTEN
 PERMISSION OF LAMBRO IS PROHIBITED.

		UNLESS OTHERWISE SPECIFIED:	NAME	DATE
		DIMENSIONS ARE IN INCHES	DRAWN	
		TOLERANCES:	CHECKED	
		FRACTIONAL ±1/16	ENG APPR.	
		ANGULAR: MACH ±1 BEND ±.01	MFG APPR.	
		TWO PLACE DECIMAL ±0.01	Q.A.	
		THREE PLACE DECIMAL ±0.005	COMMENTS:	
		INTERPRET GEOMETRIC TOLERANCING PER:	Net Free Area (NFA)	
		MATERIAL	Without Screen: 18 sq. in.	
		FINISH	With Screen: 15 sq. in.	
NEXT ASSY	USED ON	APPLICATION	DO NOT SCALE DRAWING	



4

3

2

1

A

A