

4

3

2

1

B

B

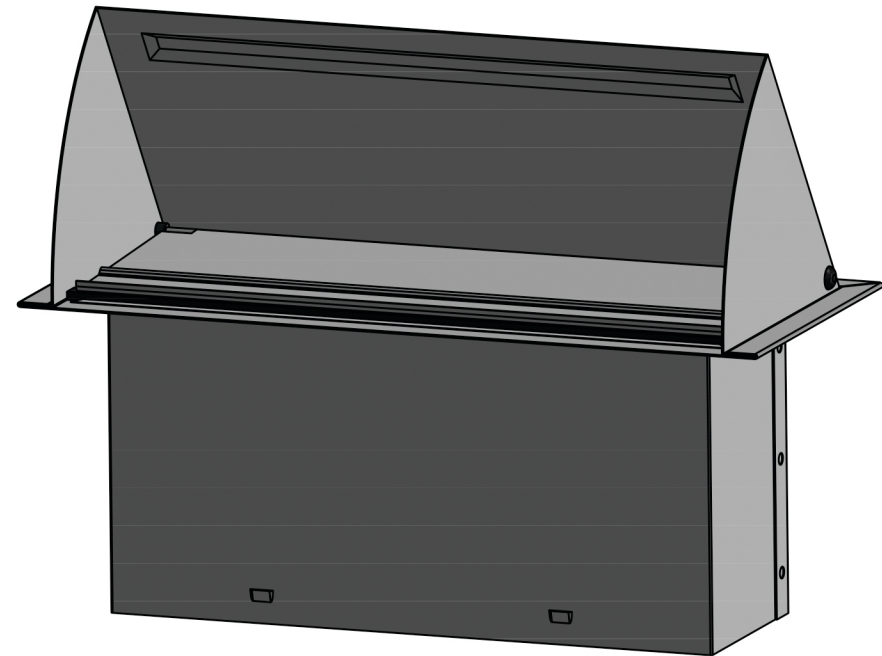
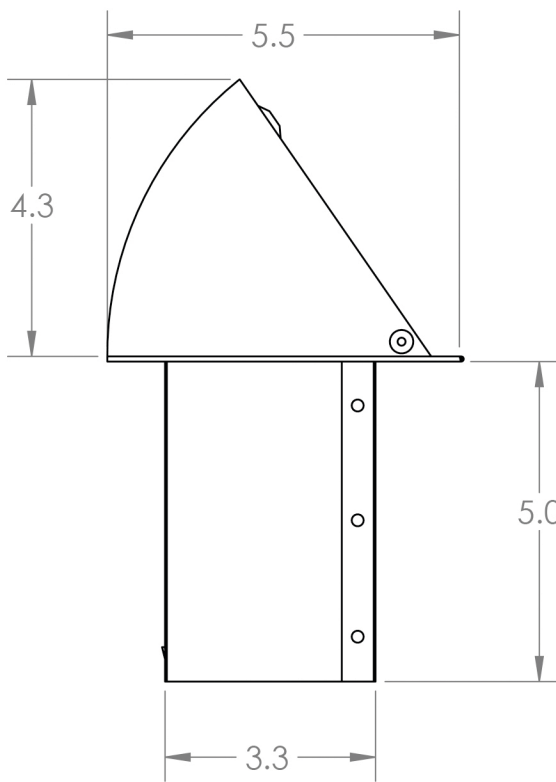
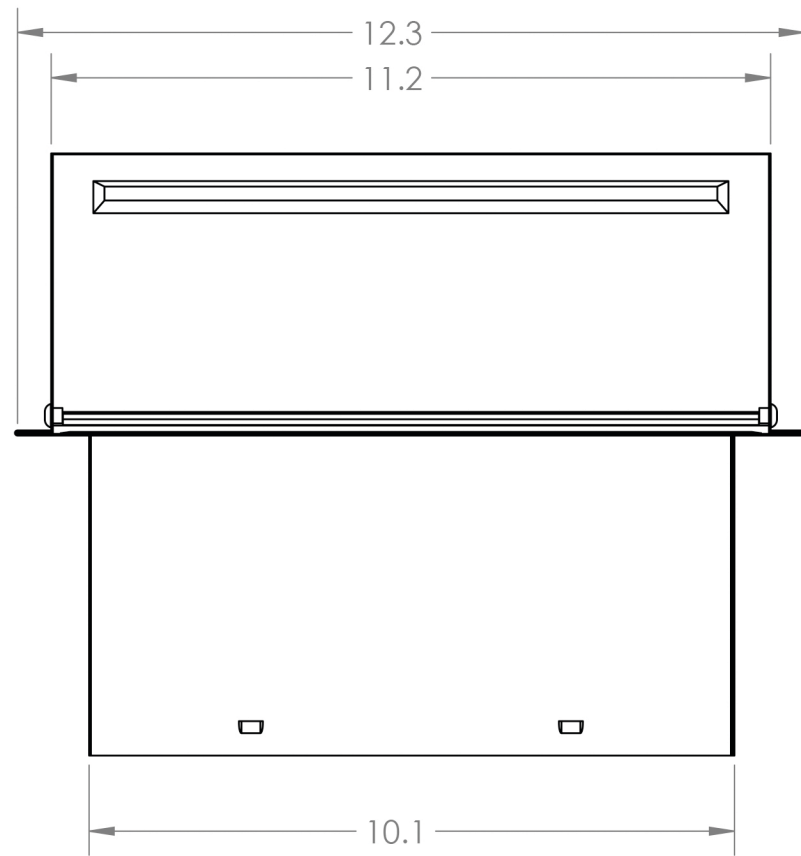

A

A



Lambro Industries, Inc.
115 Albany Ave.
Amityville, NY 11701
(631) 842-8088
www.lambro.net

PROPRIETARY AND CONFIDENTIAL
THE INFORMATION CONTAINED IN THIS DRAWING IS THE SOLE PROPERTY OF LAMBRO. ANY REPRODUCTION IN PART OR AS A WHOLE WITHOUT THE WRITTEN PERMISSION OF LAMBRO IS PROHIBITED.

		UNLESS OTHERWISE SPECIFIED:	NAME	DATE
		DIMENSIONS ARE IN INCHES	DRAWN	
		TOLERANCES:	CHECKED	
		FRACTIONAL: $\pm 1/16$	ENG APPR.	
		ANGULAR: MACH ± 1 BEND ± 0.01	MFG APPR.	
		TWO PLACE DECIMAL ± 0.01	Q.A.	
		THREE PLACE DECIMAL ± 0.005	COMMENTS:	
		INTERPRET GEOMETRIC TOLERANCING PER:	Net Free Area (NFA)	
		MATERIAL	52 sq. in.	
NEXT ASSY	USED ON	FINISH		
APPLICATION		DO NOT SCALE DRAWING		

TITLE: 3.25" x 10" Aluminum Wall Exhaust Vent - Damper
Cover & Base: 22 Gauge
Damper: 30 Gauge
Pipe: 22 Gauge

SIZE	DWG. NO.	REV
B	106R	
SCALE: 1:3	WEIGHT:	SHEET 1 OF 1

4

3

2

1