

4

3

2

1

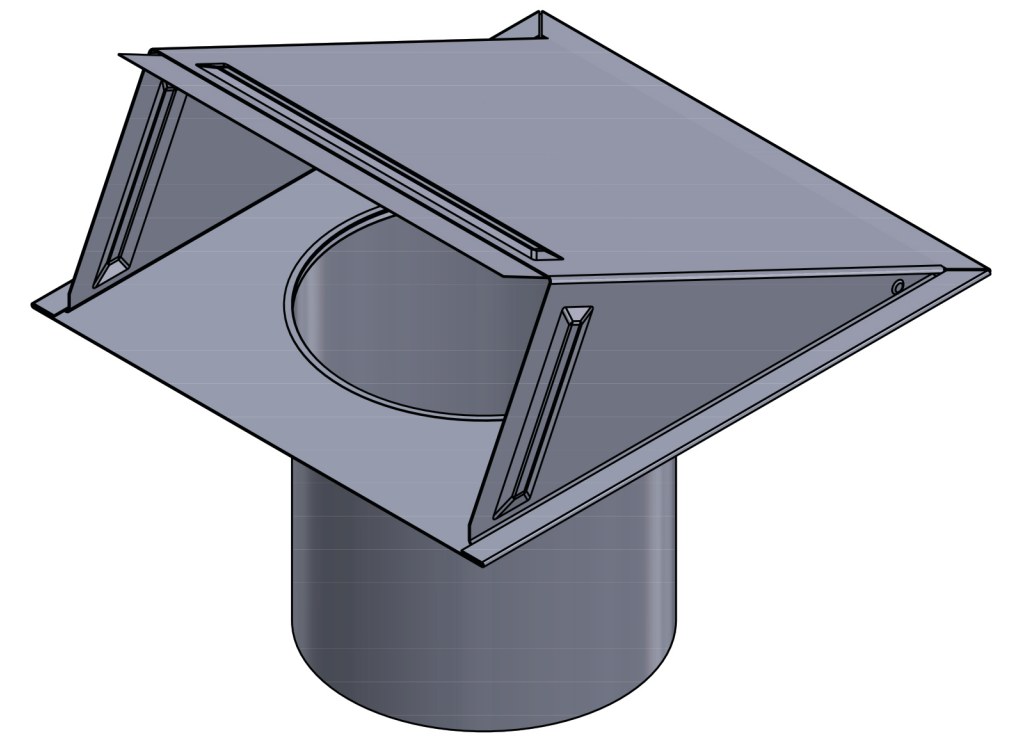
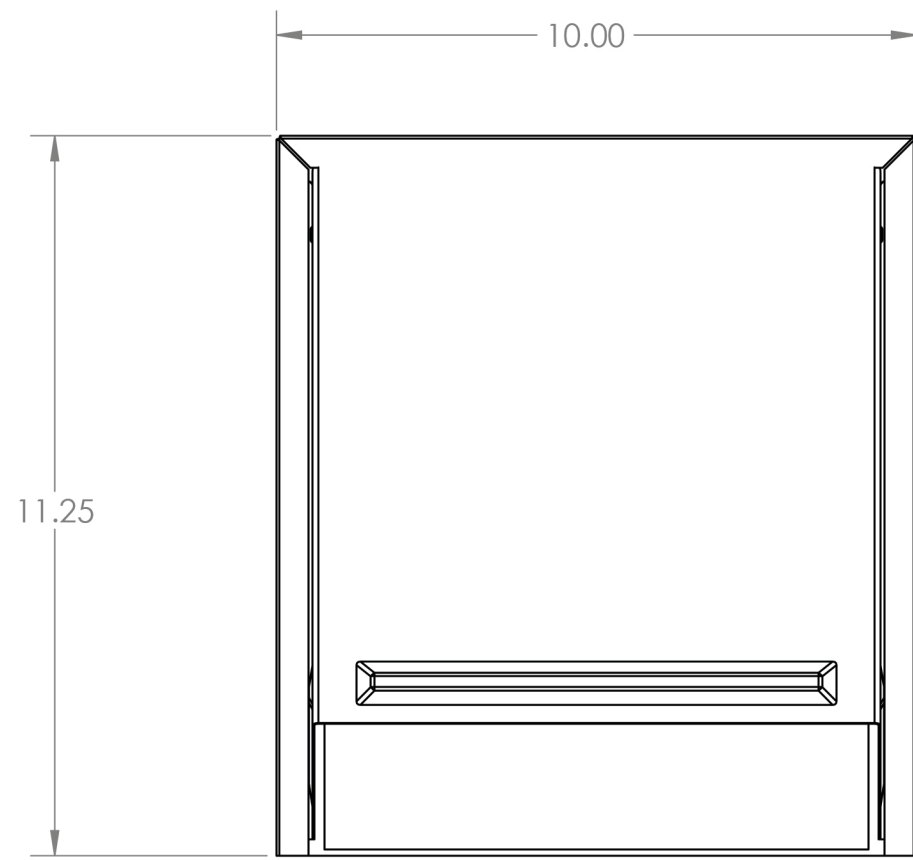

OPEN VENT

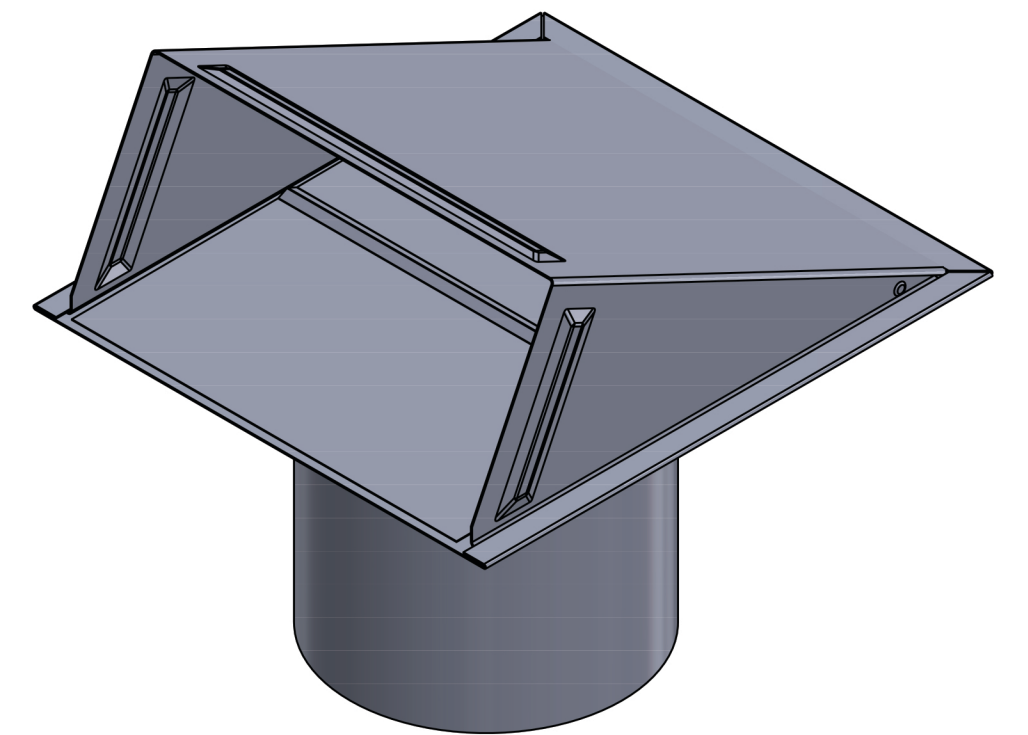
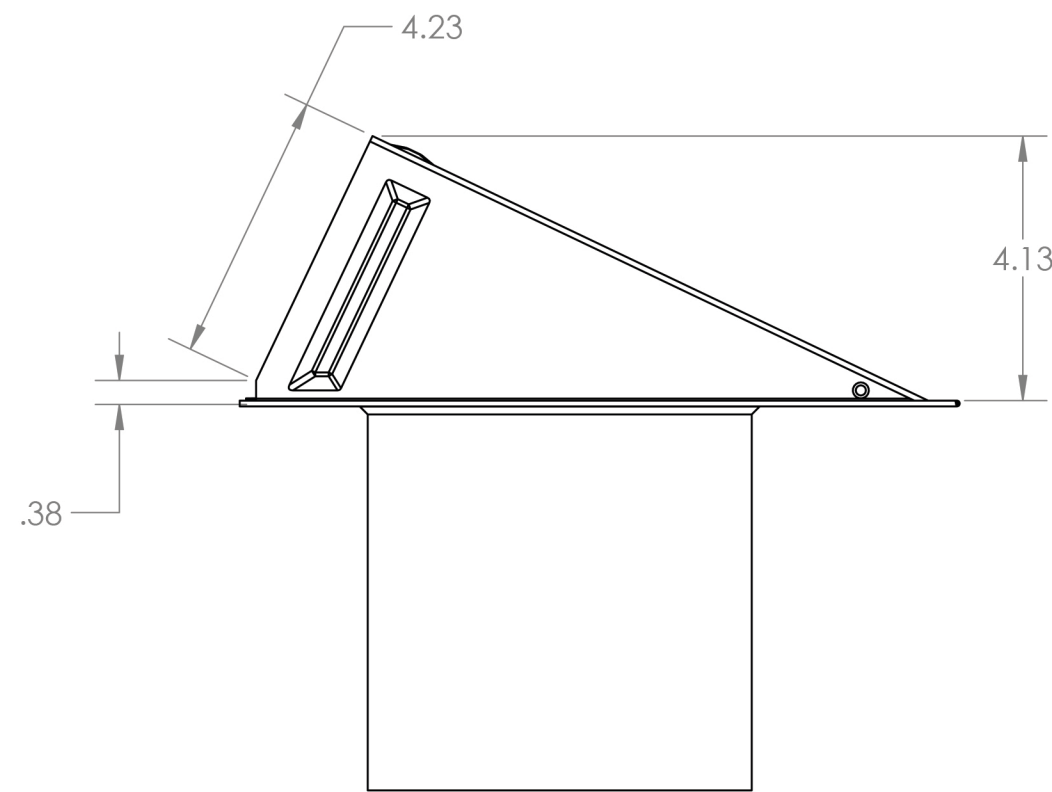
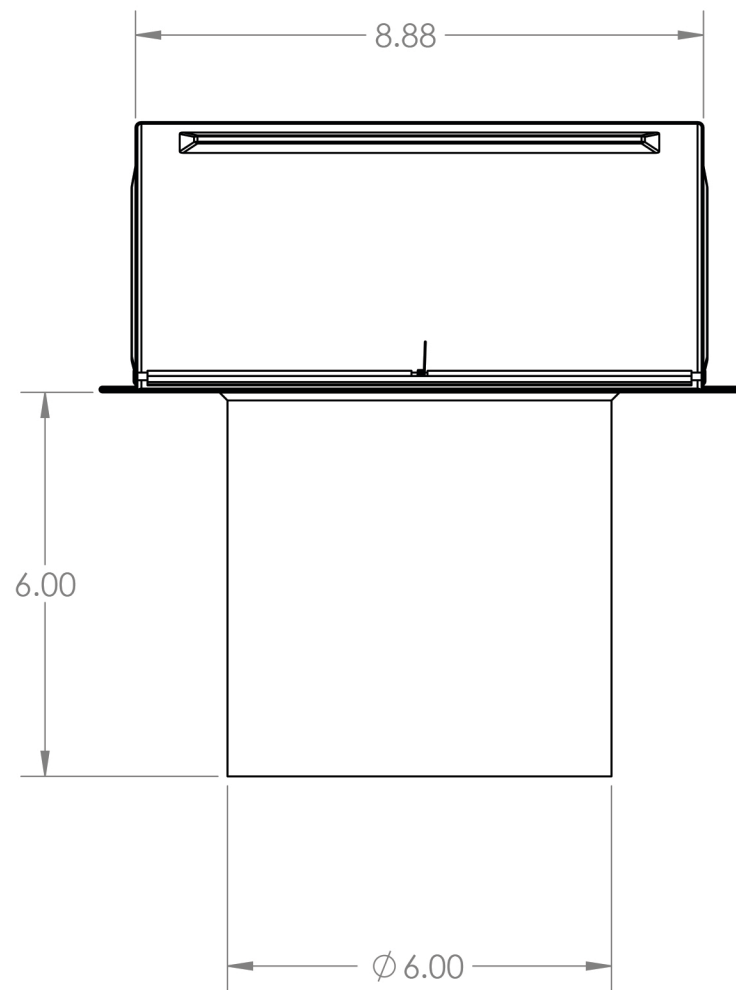

CLOSED VENT

**LAMBRO** Lambro Industries, Inc.  
 115 Albany Ave.  
 Amityville, NY 11701  
 (631) 842-8088  
 www.lambro.net

**PROPRIETARY AND CONFIDENTIAL**  
 THE INFORMATION CONTAINED IN THIS DRAWING IS THE SOLE PROPERTY OF LAMBRO. ANY REPRODUCTION IN PART OR AS A WHOLE WITHOUT THE WRITTEN PERMISSION OF LAMBRO IS PROHIBITED.

UNLESS OTHERWISE SPECIFIED:		NAME	DATE
DIMENSIONS ARE IN INCHES		DRAWN	
TOLERANCES:		CHECKED	
FRACTIONAL ± 1/16		ENG APPR.	
ANGULAR: MACH ± 1 BEND ± .01		MFG APPR.	
TWO PLACE DECIMAL ± 0.01		Q.A.	
THREE PLACE DECIMAL ± 0.005		COMMENTS:	
INTERPRET GEOMETRIC TOLERANCING PER:		Net Free Area (NFA)	
MATERIAL		40 sq. in.	
FINISH		Spring controlled damper	
NEXT ASSY	USED ON		
APPLICATION		DO NOT SCALE DRAWING	

TITLE: 6" Paint Grade Steel Wall Exhaust Hood Vent  
 Spring Damper - 6" Pipe  
 Cover, Base, Damper & Pipe: 26 Gauge

SIZE	DWG. NO.	REV
C	3460G-6-PG	
SCALE: 1:3	WEIGHT:	SHEET 1 OF 1

4

3

2

1

D

D

C

C

B

B

A

A